



PRODUCT C A T A L O G

1033 Bryn Mawr Ave
Bensenville, Illinois 60106

toll free: 800-323-8332
sales@sackettssystem.com
www.sackettssystem.com



Effective:
August 1, 2022

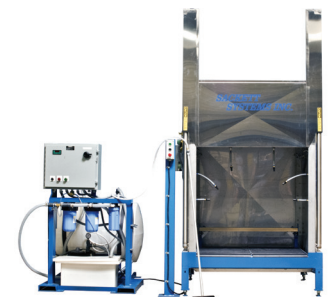

We are celebrating supporting customers for 125 years. We've been designing and manufacturing material handling equipment the way it should be - built to last. In fact, there are Sackett battery exchange systems in use around the world, some for more than 20 years, which keep operations running and businesses moving. Our equipment is designed to enhance productivity and safety, while manufactured to provide optimal uptime and lowest cost of ownership. So, are we over-engineered?

Yes, because your business depends on it!

**OUR COMPETITION
SAYS WE'RE
OVER-ENGINEERED.
WE AGREE.
BECAUSE YOUR BUSINESS DEPENDS ON IT.**

**FACTORY
WARRANTY
3x3**
3 YEARS STRUCTURAL COMPONENTS
3 YEARS ON ALL BATTERY STAND ROLLERS

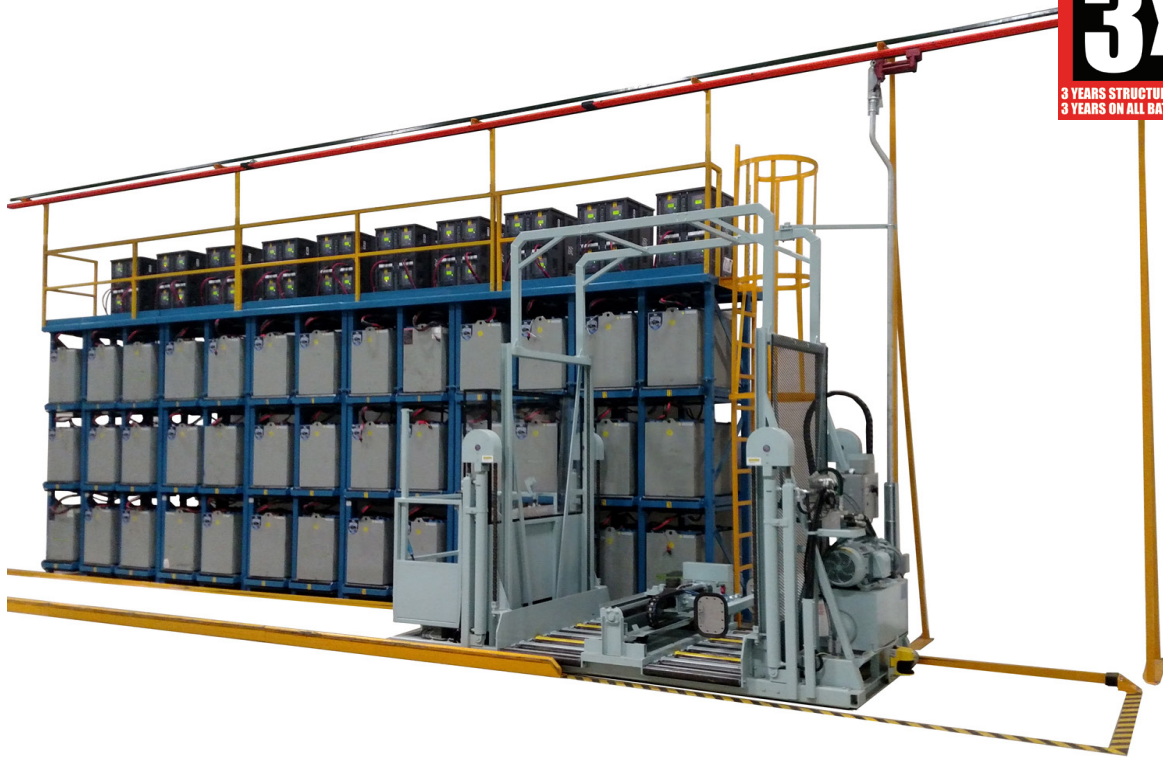

BATTERY EXCHANGE SOLUTION GUIDE

Determine which Sackett battery exchange solution is right for your operation.

Number of batteries in storage	Number of changes per day	Battery exchange solution
5 or fewer	5 to 10	Manual Transfer Cart
5 to 20	10 to 20	Powered Transfer Cart
20 to 100+	20 or more	Hydra-Handlers



Sackett Systems Inc.

Battery Exchange Equipment



At Sackett Systems, we know the importance of keeping your electric lift truck fleet moving to achieve your logistical needs at all times. Our entire line of battery exchange equipment is designed to meet, or exceed, industry standards in durability and reliability - to maximize your productivity and increase your up-time. Sackett Systems backs up this pledge with the best warranty in the industry: 3-years on structural elements and transfer rollers.

Sackett Systems has the products and services to meet your needs regardless of the size and complexity of your warehouse, logistics or manufacturing operation. From simple transfer carts, to the most complex, automated, battery exchange systems, you can count on Sackett for industry-leading quality, service, and responsiveness. Our products get the job done right, with consistent up-times, longer lifecycles, and lowest cost of ownership. Rest assured, we've got you covered day in and day out.

Sackett products have stood the test of time and in extreme operations - satisfying customers with material handling equipment for over 125 years! Many of our battery exchange systems have been in operation with satisfied customers for over 20 years.

We invite you to review this catalog for Sackett products. If you do not find what you are looking for, please contact us.

Table of Contents

About Us	Page 1
Table of Contents	Page 2
Side Removal Battery Stands	Page 3
Charger Mounting & Cable Management	Page 4
Drip Pan Kits	Page 5
Side Removal, Powered Travel, Battery Transfer	Page 6
Side Removal, Powered Travel, Battery Transfer	Page 7
Side Removal, Manual Travel, Battery Transfer	Page 8
A-Frames / Overhead Extraction	Page 9
Overhead Handling & Stands, Hoists	Page 10
Overhead Handling Accessories	Page 11
Battery Washing / Water Recycling	Page 12
Battery Room Accessories / Battery Management	Page 13
Battery Room Accessories	Page 14
Hydra-Handler Overview	Page 15

TERMINOLOGY

"R" Height or "R" Dimension = The measurement from the floor to the top of the roller in the charger stand. This height should be specified when ordering charger stands.

"R" Height or "R" Dimension also refers to the measurement from the floor to the bottom of the battery in the forklift.

Charger stand "R" Height is normally specified at the same height as the "R" Dimension of the battery in the forklift. This minimizes the need to adjust height when transferring batteries between the two.

Stand "H" Dimension = the measurement from the top of the rollers to the bottom of the charger platform. This is important for charging batteries with covers. Dimension page 10

SIDE REMOVAL BATTERY STANDS

25" Deep Charger Platform

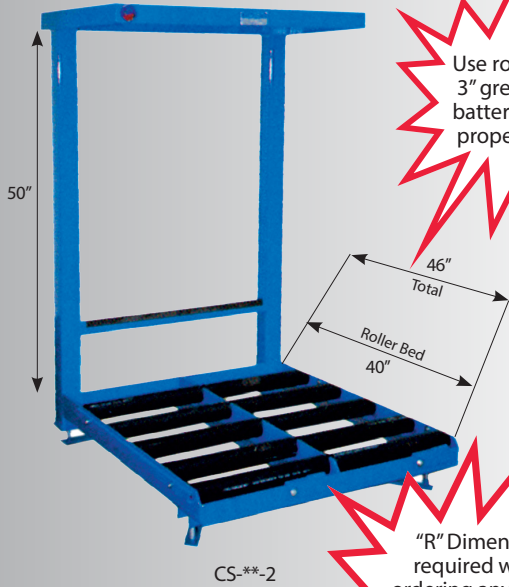

CS-**-2

Use roller width 3" greater than battery to allow proper cooling

"R" Dimension required when ordering any stand.
"R" = Floor to Top of Roller

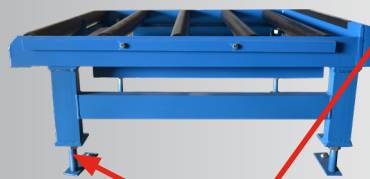

High Leg Kit

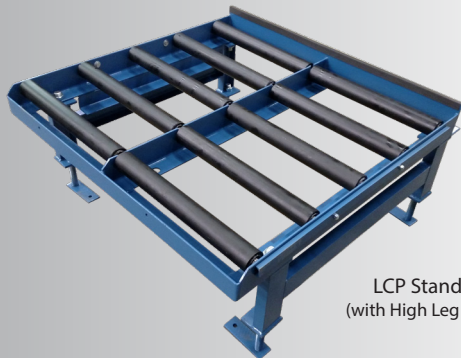

LCP Stand
(with High Leg Kit)

ROLLER CHARGING STANDS

2 COMPARTMENT

MODEL	ROLLER WIDTH	W	SHIPPING WEIGHT
CS12-2	12"	26½"	235 lbs
CS15-2	15¼"	33"	288 lbs
CS18-2	18"	38½"	313 lbs
CS21-2	21"	44½"	326 lbs
CS24-2	24"	50½"	340 lbs
CS27-2	27"	56½"	375 lbs
CS30-2	30"	62½"	395 lbs
CS33-2	33"	68½"	480 lbs
CS36-2	36"	74½"	510 lbs

3 COMPARTMENT

MODEL	ROLLER WIDTH	W	SHIPPING WEIGHT
CS12-3	12"	38¾"	280 lbs
CS15-3	15¼"	48½"	330 lbs
CS18-3	18"	56¾"	390 lbs
CS21-3	21"	65¾"	440 lbs
CS24-3	24"	74¾"	455 lbs
CS27-3	27"	83¾"	515 lbs
CS30-3	30"	92¾"	570 lbs
CS33-3	33"	101¾"	730 lbs
CS36-3	36"	110¾"	740 lbs

4 COMPARTMENT

MODEL	ROLLER WIDTH	W	SHIPPING WEIGHT
CS12-4	12"	51"	500 lbs
CS15-4	15¼"	64"	566 lbs
CS18-4	18"	75"	616 lbs
CS21-4	21"	87"	660 lbs
CS24-4	24"	99"	700 lbs
CS27-4	27"	111"	740 lbs
CS30-4	30"	123"	780 lbs
CS33-4	33"	135"	822 lbs
CS36-4	36"	147"	860 lbs

6 AND 8 COMPARTMENT

MODEL	ROLLER WIDTH	W	SHIPPING WEIGHT
CS12-6	12"	75½"	465 lbs
CS15-6	15¼"	95"	580 lbs
CS18-6	18"	111½"	750 lbs
CS21-6	21"	129½"	880 lbs
CS12-8	12"	100"	710 lbs
CS15-8	15¼"	123"	790 lbs
CS18-8	18"	147"	870 lbs

STAND OPTIONS

	Two Compartments	Three Compartments	Four Compartments
Less Charger Platform (LCP) (√)	x	x	x
45" Roller Bed (√)	x	x	x
Drip Pan Brackets	x	x	x
"R" Dimension > 8" High Leg Kit	x	x	x
Backstops Batteries < 35"	x	x	x
Flip up Stop (Part #A100016A)	x	x	x

* (√) Indicates a non-returnable item

Feature	CS Stand	ECS Stand
Upright Size	3" x 3" x 1/8"	2.5" x 2.5" x 1/8"
Battery Clearance ("H" Dimension)	50"	40"
Legs	1" Threaded Rod	3/4" Threaded Rod
"R" Dimensions	5-1/4" - 19-1/4"	5-1/8" - 8"
Bed	Rollers	Slide Strips

CHARGER MOUNTING & CABLE MANAGEMENT

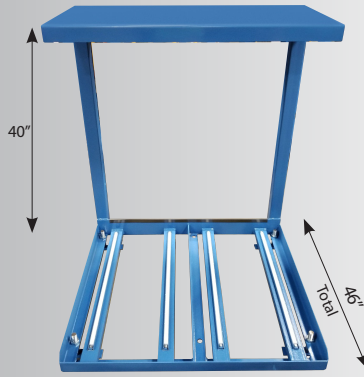

ECS-**-2



5079A

WCS-P

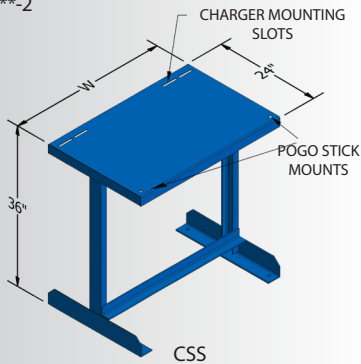

CSS

ECONOMY BATTERY CHARGING STANDS

2 COMPARTMENT

MODEL	SHIPPING WEIGHT
ECS15-2	210 lbs
ECS18-2	230 lbs
ECS21-2	250 lbs
ECS24-2	278 lbs
ECS27-2	295 lbs

3 COMPARTMENT

MODEL	SHIPPING WEIGHT
ECS15-3	318 lbs
ECS18-3	335 lbs
ECS21-3	360 lbs
ECS24-3	371 lbs
ECS27-3	425 lbs

* No Modifications allowed on Economy Stands

CHARGER SUPPORT STANDS

MODEL	W	SHIPPING WEIGHT
CSS24	24"	80 lbs
CSS36	36"	100 lbs
CSS48	48"	110 lbs
CSS72	72"	120 lbs
CSS96	96"	135 lbs
CSS120	120"	145 lbs
CSS144	144"	195 lbs
WCS-2	(Brackets Only)	30 lbs
WCS-P	(Brackets & 36" x 24" Platform)	60 lbs
B802327A	Mounting Bracket for Pogo Sticks	
CSS Stand Casters		

VERTICAL CHARGER STANDS

MODEL*	DESCRIPTION	SHIPPING WEIGHT
VCS-N	Narrow Charger Stand - Fixed	80 lbs.
VCS-S	Standard Charger Stand - Fixed	87 lbs.
VCS-W	Wide Charger Stand - Fixed	95 lbs.
VCM-C-1F0B-S	1 Charger, Single Side - Versatile	70 lbs.
VCM-C-1F1B-S	2 Charger, Dual Side - Versatile	85 lbs.
VCM-C-2F0B-S	2 Chargers, Single Side - Versatile	80 lbs.
VCM-C-2F2B-S	4 Chargers, Dual Side - Versatile	105 lbs.

*Choose welded or bolted construction. VCS = lower arm in fixed location; holds 1-2 charges. VCM = lower arm is adjustable; holds 1-4 charges.

VERTICAL CHARGER STAND DIMENSIONS

MODEL*	Dimensions				
	A	B	C	H	W
VCS-N	7" x 7"	4" - 40"	8.56" - 16.56"	60"	24"
VCS-S	7" x 7"	4" - 40"	16" - 20"	60"	28"
VCS-W	7" x 7"	4" - 40"	20" - 28"	60"	36"
VCM-1F0B	12" x 12"	4" - 40"	6" - 20"	60"	28"
VCM-1F1B	12" x 12"	4" - 40"	6" - 20"	60"	28"
VCM-2F0B	12" x 12"	4" - 40"	6" - 20"	60"	53"
VCM-2F2B	12" x 12"	4" - 40"	6" - 20"	60"	53"

*Choose welded or bolted construction. VCS = lower arm in fixed location; holds 1-2 charges. VCM = lower arm is adjustable; holds 1-4 charges.



VCS - Narrow

VCS - Wide

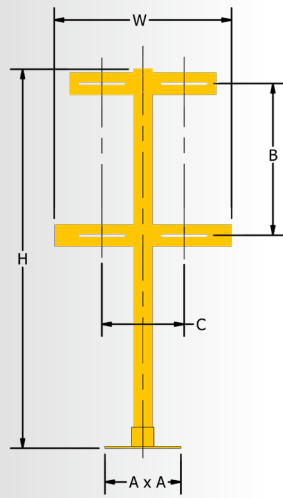

VCS/VCM DIMENSIONS

POGO STICKS - Cable Retractor

MODEL	SHIPPING WEIGHT
5079A (24" Pogo w/chain & suspender)	6 lbs
5079B (40" Pogo w/ Enclosed Spring)	7 lbs
5079 (40" Pogo w/chain & suspender)	7 lbs
1769 (40" Pogo Stick basic)	6 lbs
B802327A Pogo Stick Bracket	1 lb

CHARGER CABLE SUSPENSION

MODEL	SHIPPING WEIGHT
808078A Pogo Pole	10 lbs
3495 Wall Mounted	4 lbs



1769 5079

Pogo Sticks



808078A

Pogo Pole

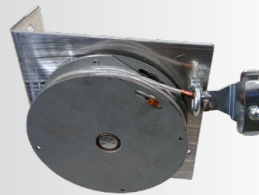

3495

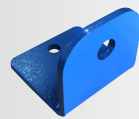

B802327A

DRIP PAN KITS

Protect your investment with Drip Pan Kits

Drip Pan Kits should be considered for all battery charging stands. Drip Pans capture and contain spills of electrolyte that can occur during the charging of industrial batteries. Drip Pan Kits meet the containment requirements of OSHA Regulation 1926.441 (a) (3). Sackett Systems offers high density polyethylene drip pans because of its superior resistance to acid and electrolyte solutions. Drip Pans can be custom-sized for any stands. Stainless steel drip pans are also available upon request.



Battery Service Stands (BSS)

Removable Drip Pans for easy cleanup and protection.

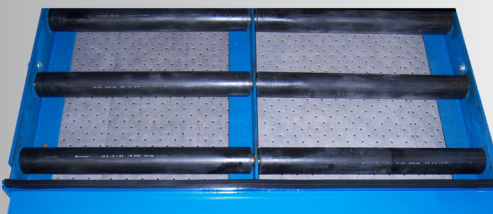

Drip Pan Absorbent Pad (see page 13)

SINGLE LEVEL DRIP PAN KITS

2 COMPARTMENT

- PART #
- CS12-2-DPK-P
 - CS15-2-DPK-P
 - CS18-2-DPK-P
 - CS21-2-DPK-P
 - CS24-2-DPK-P
 - CS27-2-DPK-P
 - CS30-2-DPK-P
 - CS33-2-DPK-P
 - CS36-2-DPK-P

3 COMPARTMENT

- PART #
- CS12-3-DPK-P
 - CS15-3-DPK-P
 - CS18-3-DPK-P
 - CS21-3-DPK-P
 - CS24-3-DPK-P
 - CS27-3-DPK-P
 - CS30-3-DPK-P
 - CS33-3-DPK-P
 - CS36-3-DPK-P

4 COMPARTMENT

- PART #
- CS12-4-DPK-P
 - CS15-4-DPK-P
 - CS18-4-DPK-P
 - CS21-4-DPK-P
 - CS24-4-DPK-P
 - CS27-4-DPK-P
 - CS30-4-DPK-P
 - CS33-4-DPK-P
 - CS36-4-DPK-P

6 COMPARTMENT

- PART #
- CS12-6-DPK-P
 - CS15-6-DPK-P
 - CS18-6-DPK-P

8 COMPARTMENT

- PART #
- CS12-8-DPK-P
 - CS15-8-DPK-P
 - CS18-8-DPK-P

BATTERY SERVICE STANDS

MODEL	ROLLER WIDTH	W	SHIPPING WEIGHT
BSS15	15"	17½"	100
BSS21	21"	23½"	125
BSS24	24"	26½"	140

* R=Roller Height * Please specify desired height

BATTERY SERVICE STANDS DRIP PAN KITS

- MODEL
- BSS15-DPK-P
 - BSS21-DPK-P
 - BSS24-DPK-P

SIDE REMOVAL, POWERED TRAVEL, BATTERY TRANSFER



A-PJTC



B-PJTC

(Powered Extraction)

*Drive under base or Fork Pocket
Also Available



C-PJTC



E-PJTC



X-CHANGER (XTC)

TRANSFER CARTS - PALLET JACK MOUNTED

MODEL	SHIPPING WEIGHT
A-PJTC24	625 lbs
B-PJTC24	717 lbs
B-PJTC30	740 lbs
B-PJTC36	840 lbs
C-PJTC24	1025 lbs
C-PJTC30	1100 lbs
C-PJTC36	1250 lbs
E-PJTC24	720 lbs
E-PJTC30	745 lbs
E-PJTC36	845 lbs

OPTIONS	MODEL			
	A	B	C	E
Customizable Roller Bed, length of 45" or 50" (40" standard)	X	X	X	X
Drive Under Base (not mounted to pallet jack)	X	X		X
Fork Pockets (90° for forklift use) (36-Volt Controls recommended)		X		X
Removable Slide Bed		X		X
Battery Pack - (2) 12-volt Batteries		X		X
Battery Charger		X		X
4 Button Pendant		X		X
Factory Mounted to Supplied Pallet Jack	X	X	X	X
High "R" Spacer - > 12-1/2" R (Transfer Height)	X	X		X
36-volt Hook & Pull Only	X	X		X
36-volt Controls with Y-Connector & Magnet or Vacuum	X	X		X
Bolt / Clamp Kit for PJTC to the Pallet Jack	X	X		X
Drop-In Roller Bed for Dual Transfer Heights		X		X
Optional Battery Guides for Narrow Batteries (to ensure safe transfer)		X		X
Audible Sound and Light While Magnet On (various configurations available)		X	X	X

TRACK MOUNTED TRANSFER CARTS

DC POWERED

MODEL	SHIPPING WEIGHT
XTC24	1405 lbs
XTC30	1420 lbs
XTC36	1430 lbs

XTC FEATURES:

· On-Board 24Volt DC, DC battery system included · No Operator Compartment

AC POWERED

MODEL	SHIPPING WEIGHT
XTC24-AC	1405 lbs
XTC30-AC	1420 lbs
XTC36-AC	1430 lbs

OPTIONS:

AC units require Cable Reel or Buss

Track, 1½" Flat (Part #B800361A)

5" minimum "R" dimension

Side Operator Platform (specify left (std) or right) PTC Only

SIDE REMOVAL, POWERED TRAVEL, BATTERY TRANSFER



XTE-36

EMERALD BATTERY EXCHANGE SYSTEM

ALL ELECTRIC

MODEL
XTE-36

SHIPPING WEIGHT
1500 lbs



HPT

Shown w/ High "R" Spacer

TRANSFER CARTS -HEAVY DUTY

PALLET JACK MOUNTED

MODEL
HPT24
HPT30
HPT36
HPT42

SHIPPING WEIGHT
1200 lbs
1245 lbs
1385 lbs
1455 lbs

OPTIONS:

45" or 50" Roller Bed (require longer forks)
High-R Spacer



HPT-PL

PALLET JACK MOUNTED WITH POWERED LIFT

MODEL
HPT30-PL
HPT36-PL
HPT42-PL

SHIPPING WEIGHT
1230 lbs
1300 lbs
1370 lbs

SIDE REMOVAL, MANUAL TRAVEL, BATTERY TRANSFER

BEST OPTION FOR BACK UP BATTERY EXCHANGE EQUIPMENT FOR MULTI-LEVEL STANDS



HFT

FORK MOUNTED (HEAVY DUTY) MAGNET or VACUUM with Y-Connector

MODEL	SHIPPING WEIGHT
HFT30-Y	1250 lbs
HFT36-Y	1400 lbs
HFT42-Y	1475 lbs

Options

45" or 50" Roller Bed
Hydraulic Flip Up Stop



TC**-PN

ROLLER TRANSFER CARTS

PUSH/PULL PLATE

MODEL	SHIPPING WEIGHT
TC24-PN	770 lbs
TC30-PN	820 lbs

HYDRAULIC POWERED LIFT AND EXTRACTION WITH VACUUM



PTC

MODEL	SHIPPING WEIGHT
PTC24	997 lbs
PTC30	1045 lbs

OPTIONS (For All TC Carts)

45" Roller Bed
Roll Back Brake Kit (Part #B804197) 2 floor locks & mount pads

OPTIONS: (For Powered TC Carts)

MODEL	SHIPPING WEIGHT
Charger (Part #4926A) 24v for use with magnet	12 lbs
No Battery Pack (2) 6 Volt Batteries	

A-FRAMES / OVERHEAD EXTRACTION

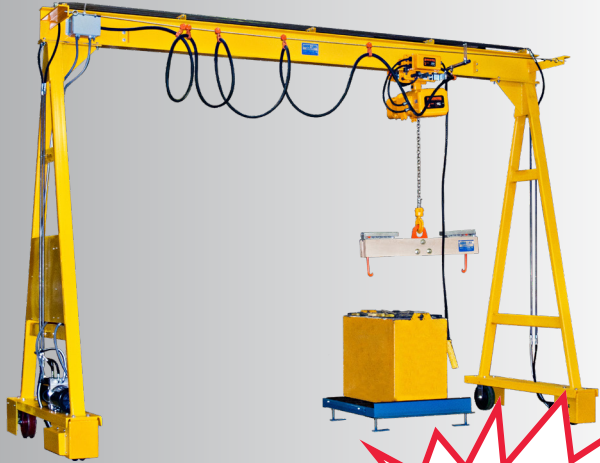

PTAF

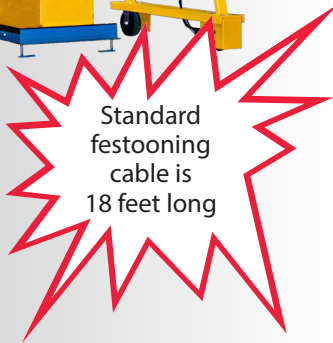

A-FRAME USAGE CHART

MODEL	WHEELS	DRIVE TYPE	APPLICATION
PAF	Portable A-Frame with Swivel Casters	Manual	Battery Maintenance Area
TAF	Track Mounted	Manual	Light Duty Overhead Battery Changing
PTAF	Track Mounted	Powered	Standard and Heavy Duty Battery Changing

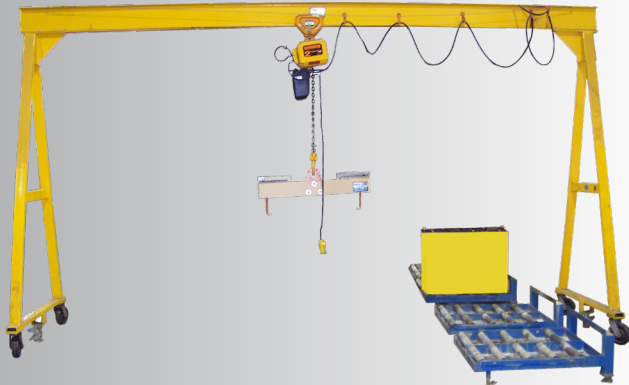

PAF

2 TON A-FRAMES

2 TON PORTABLE "A" FRAME

MODEL	SHIPPING WEIGHT
PAF10-2T ✓	728 lbs
PAF12-2T ✓	774 lbs
PAF14-2T ✓	856 lbs
PAF16-2T ✓	907 lbs
PAF18-2T ✓	1140 lbs
PAF20-2T ✓	1143 lbs

* (✓) Indicates a non-returnable item

2 TON MANUAL TRAVELING A-FRAME

MODEL	SHIPPING WEIGHT
TAF10-2T ✓	818 lbs
TAF12-2T ✓	864 lbs
TAF14-2T ✓	946 lbs
TAF16-2T ✓	997 lbs
TAF18-2T ✓	1230 lbs
TAF20-2T ✓	1233 lbs

* (✓) Indicates a non-returnable item

2 TON POWERED TRAVELING A-FRAME

MODEL	SHIPPING WEIGHT
PTAF10-2T ✓	1661 lbs
PTAF12-2T ✓	1707 lbs
PTAF14-2T ✓	1789 lbs
PTAF16-2T ✓	1840 lbs
PTAF18-2T ✓	1873 lbs
PTAF20-2T ✓	1876 lbs
PTAF22-2T ✓	2395 lbs

* (✓) Indicates a non-returnable item

3 TON A-FRAMES

3 TON PORTABLE "A" FRAME

MODEL	SHIPPING WEIGHT
PAF10-3T ✓	728 lbs
PAF12-3T ✓	805 lbs
PAF14-3T ✓	1000 lbs
PAF16-3T ✓	1016 lbs
PAF18-3T ✓	1197 lbs
PAF20-3T ✓	1273 lbs

* (✓) Indicates a non-returnable item

3 TON MANUAL TRAVELING A-FRAME

MODEL	SHIPPING WEIGHT
TAF10-3T ✓	818 lbs
TAF12-3T ✓	895 lbs
TAF14-3T ✓	1090 lbs
TAF16-3T ✓	1106 lbs
TAF18-3T ✓	1287 lbs
TAF20-3T ✓	1363 lbs

* (✓) Indicates a non-returnable item

3 TON POWERED TRAVELING A-FRAME

MODEL	SHIPPING WEIGHT
PTAF10-3T ✓	1803 lbs
PTAF12-3T ✓	1880 lbs
PTAF14-3T ✓	2075 lbs
PTAF16-3T ✓	2091 lbs
PTAF18-3T ✓	2272 lbs
PTAF20-3T ✓	2348 lbs
PTAF22-3T ✓	2769 lbs

* (✓) Indicates a non-returnable item

A-FRAME OPTIONS

Poly Wheel - one side (PTAF Only)
Single-Sided Track (PTAF Only) (Part # B800361)- with poly wheel option
Dual Track (Recommended)
Railroad Crossing
12' Under Beam (standard on 3 ton units)
13 ft & Higher Under Beam
Festooning (on TAF only)
Hoist/Trolley not included in price (See Page 10)

OVERHEAD HANDLING & STANDS, HOISTS

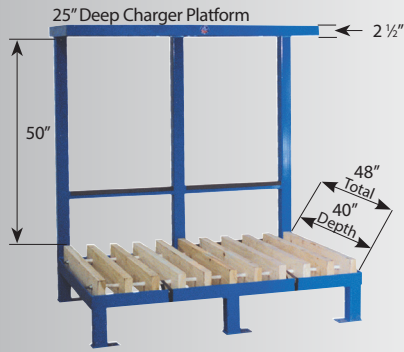

CS**-P



CS**-P
(Plastic Inserts)



Hoist Part #7239



Cable Reels

HDPE CHARGING STANDS

MODEL	WIDTH	SHIPPING WEIGHT
CS30-P	32"	310 lbs
CS42-P	44"	340 lbs
CS60-P	62"	475 lbs
CS72-P	74"	510 lbs
CS84-P	86"	560 lbs
CS90-P	90"	590 lbs
CS96-P	96"	620 lbs
CS100-P	100"	640 lbs
CS120-P	120"	665 lbs
CS144-P	144"	740 lbs

*Wood inserts available upon request

OPTIONS:

45" Bed

Left to Right Poly inserts > 100" recommended for batteries less than 13" wide

"LCP" Less charger Platform** deduct

HDPE STAND DRIP PAN KITS

PART NUMBER	PART NUMBER
CS30-P-DPK-P	CS90-P-DPK-P
CS42-P-DPK-P	CS96-P-DPK-P
CS60-P-DPK-P	CS100-P-DPK-P
CS72-P-DPK-P	CS120-P-DPK-P
CS84-P-DPK-P	CS144-P-DPK-P

HOISTS

2-Ton Electric (480v, 3ph)

PART #	DESCRIPTION	SHIPPING WEIGHT
7238	Motorized Trolley, chain container, 4-button pendant (TAF, PAF)	240 lbs
7239	Motorized Trolley, chain container, 6-button pendant (PTAF)	240 lbs

3-Ton Electric (480v, 3ph)

PART #	DESCRIPTION	SHIPPING WEIGHT
7241	Motorized Trolley, chain container, 4-button pendant (TAF, PAF)	311 lbs
7242	Motorized Trolley, chain container, 6-button pendant (PTAF)	311 lbs

CABLE REELS FOR A-FRAME SYSTEM

PART NUMBER	DESCRIPTION
6296	30-ft. w/Guide Arm
6295	50-ft. w/Guide Arm
6300	70-ft. w/Guide Arm

*Specify wall construction type when ordering.

OVERHEAD HANDLING ACCESSORIES

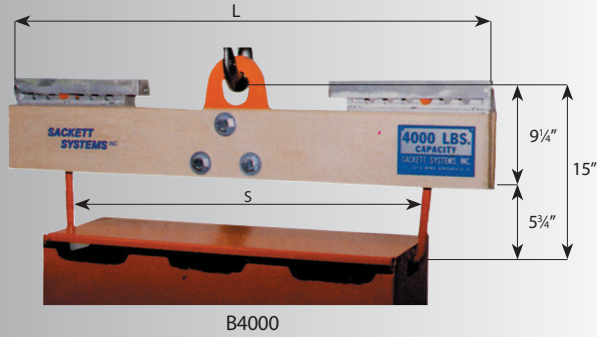

B4000

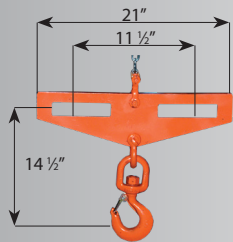

BFA6000



807360
(Battery Lifting Beam Stand)



B800482-1
(Safety Hook)

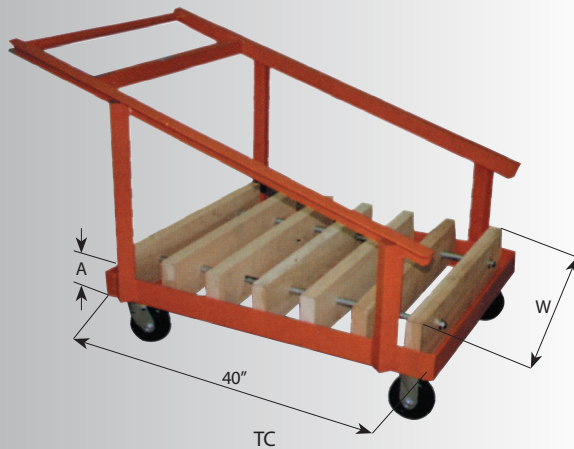

TC

BATTERY LIFTING BEAMS

MODEL	CAPACITY	L	S	SHIPPING WEIGHT
B4000	4000 lbs	43"	24"-39"	52 lbs
B6000	6000 lbs	47"	28"-43"	60 lbs
B4000SH w/ safety hook	4000 lbs	43"	24"-39"	55 lbs
B6000SH w/ safety hook	6000 lbs	47"	28"-43"	63 lbs

5 OR MORE

MODEL	CAPACITY	L	S	SHIPPING WEIGHT
B4000	4000 lbs	43"	24"-39"	52 lbs
B6000	6000 lbs	47"	28"-43"	60 lbs
B4000SH w/ safety hook	4000 lbs	43"	24"-39"	55 lbs
B6000SH w/ safety hook	6000 lbs	47"	28"-43"	63 lbs

Other designs available – Contact Sackett

BEAM FORK ATTACHMENT

MODEL	SHIPPING WEIGHT
BFA6000	28 lbs
Lifting Beam Stand (Part #807360)	Lifting Beam Stand

SAFETY HOOK ASSEMBLY

MODEL	DESCRIPTION
B800482-1	Safety Hook Assembly (2 safety hooks)

HDPE TRANSFER CARTS

MODEL	W	A	SHIPPING WEIGHT
TC20-W	21 1/2"	12 3/4"	250 lbs
TC30-W	31 1/2"	12 3/4"	293 lbs
TC40-W	41 1/2"	12 3/4"	335 lbs

WITH ROLLER BED

MODEL	W	A	SHIPPING WEIGHT
TC20-R	21 1/2"	TBD	220 lbs
TC30-R	31 1/2"	TBD	260 lbs

Add \$175 for Outriggers if "A" is under 10 1/4"

BATTERY WASHING / WATER RECYCLING

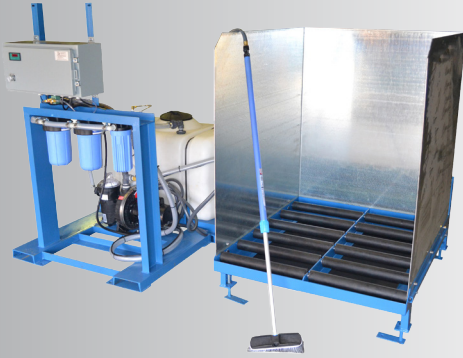

WR-1RW-WRS



MODEL A w/WRS



MODEL B

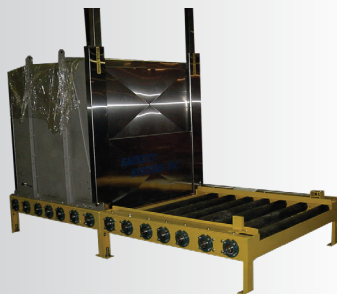

MODEL B+



WRS-Base Unit

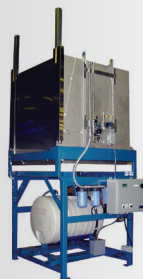

BOW

MANUAL BATTERY WASHERS

MODEL	WIDTH	DEPTH	SHIPPING WEIGHT
WR-1 Plastic Inserts Wash Rack	45"	48"	645 lbs
WR-1R Roller Wash Rack	45"	51½"	660 lbs

MODEL

WR-1-P Portable Wash Rack, 3-sided galvanized HDPE wash rack

WR-1R-P Portable Wash Rack, 3-sided galvanized roller wash rack

OPTIONS:

Low "R" dimension for use with Pallet Jack carts + WRS

Handheld Scrub Brush w/hose

Rear Casters & Lift Jack Handle

Fork Extensions 5 ft Long

Brush, Nylon 5' Handle 3/4(F) Garden Hose Connector (Part #4836B)

AUTOMATIC BATTERY WASHERS

MODEL	SHIPPING WEIGHT
A: (Gravity/Unpowered Rollers/Powered Door)	1330 lbs
B: (Powered Rollers/Powered Door)	1870 lbs
B+: (Powered Conveyor Rollers/Powered Door)	2905 lbs
Air Compressor 5497 (use with Automatic Battery Washer)	500 lbs

COMBOS

MODEL	SHIPPING WEIGHT
Model A with WRS & Scrub Brush	2085 lbs
BOW (WRS mounted under Washer)	2100 lbs
WR w/ WRS (with scrub brush)	1500 lbs

OPTIONS:

Brush, Bottom Scrub AWC Conveyor, 63-1/2 X 42" Brush (Part #A801194)

Brush, Nylon 5' Handle 3/4(F) Garden Hose Connector (Part #4836B)

11" "R" dimension for Pallet Jack carts (Model A)

5 gal Conditioner (Part #4228) (not for use with WRS)

Air Compressor (Part #5497)

WATER RECIRCULATING SYSTEM

MODEL	SHIPPING WEIGHT
WRS- Base Unit	755 lbs

PARTS & ACCESSORIES:

5 gal Neutralizer Concentrate (Part #8054 for use with WRS)

Deionizer (Part #6305)

Extra Filler Cartridges (Part #6306)

Filter 30 mic (Part #4660)

Filter Active Carbon 5 mic (Part #4611)

CONTACT SACKETT FOR HYDRA-HANDLERS
AND ALL MULTI-STACKING SYSTEMS

BATTERY ROOM ACCESSORIES / BATTERY MANAGEMENT



8724
10-gal. Water Cart



1749
Automatic Watering Gun



7862C/9585
Spill Kit



8842
Safety Kit



6529
Shower & Eye Wash

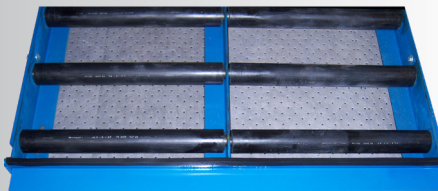

9710-1
Drip Pan Absorbent Pad



SBM



RD-100 (Part #7006)

BATTERY MAINTENANCE

MODEL	DESCRIPTION	SHIPPING WEIGHT
1749	Automatic Watering Gun	1.5 lbs
6305	Deionizer	28 lbs
5504	20-ft Hose	35 lbs
4476	50-ft Hose	70 lbs
6306	Extra Filler cartridge (Deionizer)	14 lbs
8724	10-gal. Water Cart 12 VDC (battery included) (does not include Automatic Watering Gun)	30 lbs

SAFETY EQUIPMENT

MODEL	DESCRIPTION
8842	Safety Equipment Kit Includes (2) 15ml Vinyl Aprons, (2) sets of gloves & HeadGear
6529	Shower & Eye Wash
6580	Eye Wash Wall Mounted (portable)
6767	Personal Eye Wash, w/saline-filled bottle
7862C	Spill Kit 6 Gallons
9585	Spill Kit 1/2 gallon

SAFETY SIGNAGE

MODEL	DESCRIPTION
9712-1	Pack of 9 Safety Signs

ACID ABSORBING AND NEUTRALIZING PADS & PILLOWS

MODEL	DESCRIPTION
9710-1	Neutralizing Pads 11"x12" (pack of 25)

BATTERY MANAGEMENT

MODEL	DESCRIPTION
7006	Red, Yellow, and Green light indicator
7006-80	80v
7006-Dual	2 readouts / housing
Battery Management Systems	

SACKETT BATTERY MANAGEMENT

MODEL	DESCRIPTION
SBMLite	Up to 50 Chargers 1 Battery Pool
SBMPlus	Up to 100 Chargers 9 Battery Pools
SBMPro	Up to 350 Chargers 9 Battery Pools

The SBM with Real-Time Monitor enables the most cost-effective utilization of your pool of batteries. It ensures proper battery rotation, which is critical to long battery life and maximum run time. SBM monitors all batteries in a pool and eliminates operator judgement in battery selection by determining which battery has had the longest cooling time since charging. Once charged, each battery is placed in a queue. The simple-to-use SBM "read and react" Display then tells the operator which battery to take. An audible alarm called the Shouter alerts the operator when the wrong battery is taken. And the Real-Time Monitor provides all the information needed to efficiently manage the battery pool.

BATTERY ROOM ACCESSORIES



SACKETT SAFETY RAIL

MODEL	DESCRIPTION
Sackett Safety Rail Single ✓	Single Safety Rail with Columns included
Sackett Safety Rail Double ✓	Double Safety Rail with Columns included

* (✓) Indicates a non-returnable item



DUAL LEVEL CHARGER SUPPORT STANDS

MODEL	DESCRIPTION
Various Models Available ✓	

* (✓) Indicates a non-returnable item



HYDROGEN DETECTOR

MODEL	DESCRIPTION
9159	Hydrogen Gas Detector

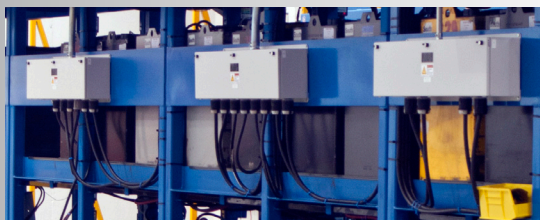

PDP POWER DISTRIBUTION PANEL

MODEL	DESCRIPTION
8682-30	Eight Position Power Distribution Panel - 30 Amps
8682-20	Eight Position Power Distribution Panel - 20 Amps
8681-30	Six Position Power Distribution Panel - 30 Amps
8681-20	Six Position Power Distribution Panel - 20 Amps
8680-30	Four Position Power Distribution Panel - 30 Amps
8680-20	Four Position Power Distribution Panel - 20 Amps

The PDP5000 is a modular power distribution panel that is mounted directly to Sackett Systems' stands at the facility.

Reduce the number of conductors pulled from the main panel from one per charger, to one per stand. UL Rated.

THIS IS HOW THE BEST RUN COMPANIES STAY UP AND RUNNING.

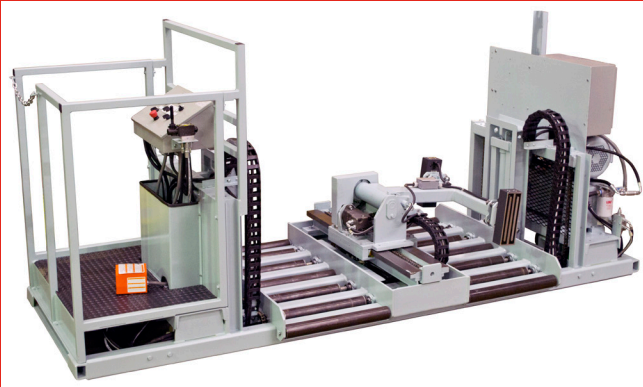

HYDRA-HANDLER SUPER

This narrow footprint, single stack battery changer with one or two compartments can be powered via AC operating voltage. Converting from a narrow aisle changer, manual or pallet jack mounted battery exchange system to the Hydra-Handler Super can cut battery change times in half.

HYDRA-HANDLER SELECT

As Sackett's flagship operator-on-board battery handler, the Select features a unique heavy duty rack and pinion extractor arm, 2" (51mm) axles and 10 HP motor for a unit that has field-proven durability and reliability. With industry-leading, built-in safety features and vacuum or magnet extraction, the Hydra-Handler Select can be customized for systems one to 3-high.

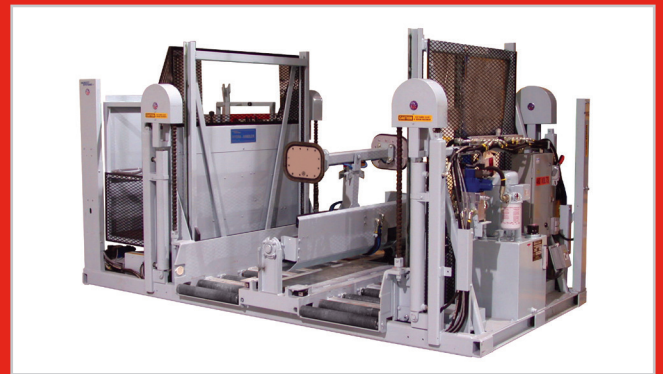

Industry
4.0
Capable



HYDRA-HANDLER MAX

With all the quality capabilities of the Hydra-Handler Select, the Max features PLC controlled hydraulic valves which allow for faster lift, smoother starts and stops, easier feathering of the controls and adjustability of the lift and travel functions. The valves also facilitate troubleshooting with built-in indicator lights. The Hydra-Handler Max can be configured for 1-high to 5-high stacking applications and is the ideal Hydra-Handler in high-volume battery changing operations.

HYDRA-HANDLER ELITE

Dramatically increase efficiency and reduce labor costs with the Hydra-Handler Elite. Forklift operators are able to safely and quickly change their own batteries while laser photo eyes and ultrasonic sensors eliminate damage to equipment. Battery changes happen faster, because the system automatically travels to pre-programmed battery changing positions. Plus, the First-In, First-Out battery management software maximizes battery life and reduces the amount of batteries required.

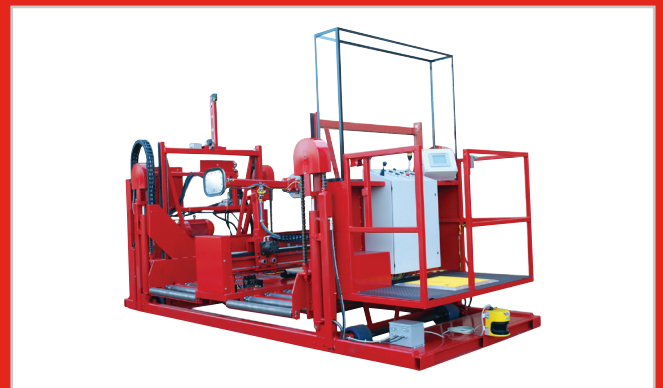

SACKETT
WE KEEP YOUR BUSINESS MOVING